



ProLight AL6A-RA1DF-D2
0.5W Power LED
Technical Datasheet
Version: 1.1

ProLight Opto AL6A Series

Features

- Moisture Sensitivity : JEDEC Level 2
- RoHS compliant
- Lead free reflow soldering
- AEC-Q102 compliant

Main Applications

- Backlighting
- Signaling
- Exterior Automotive Lighting
- Automotive Interior Lighting

Automotive

Introduction

·AL6A offer red color solution to meet the needs of backlighting, signaling, exterior automotive lighting, and automotive interior lighting. Along with high-quality materials, AL6A bring not only high performance but also good reliability to fulfil customer's requirements.

Emitter Mechanical Dimensions

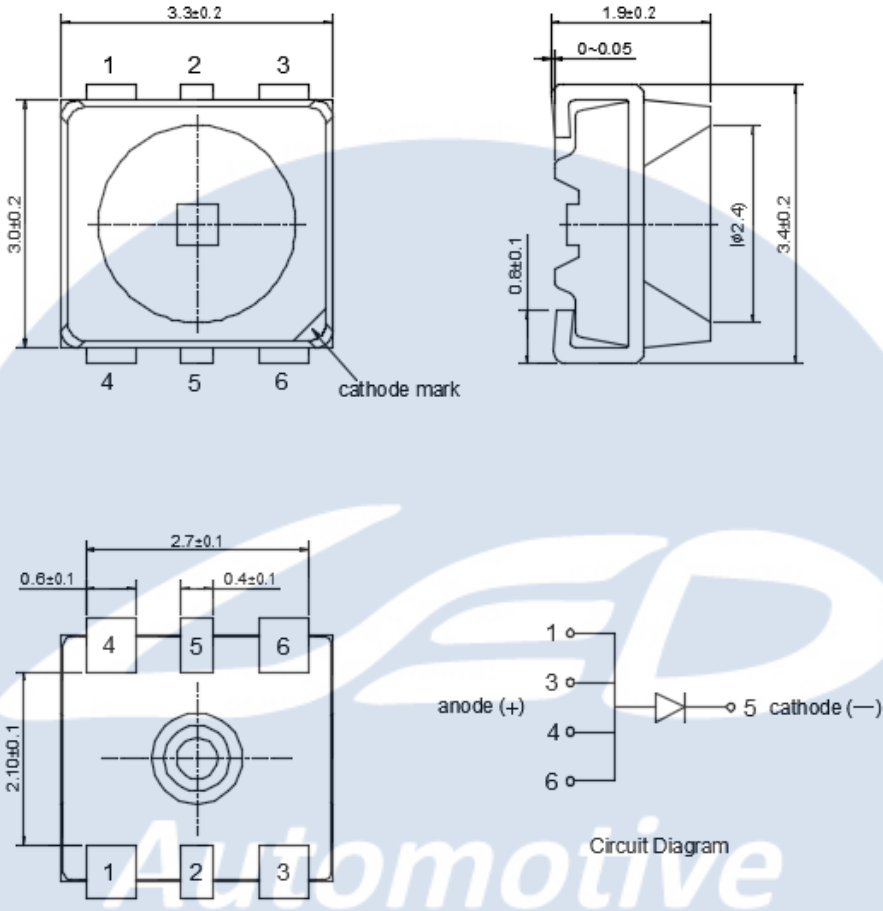

Notes:

1. The cathode side of the device is denoted by the chamfer on the part body.
2. Drawing not to scale.
3. All dimensions are in millimeters.
4. Unless otherwise indicated, tolerances are ± 0.1 mm.
5. Please do not solder the emitter by manual hand soldering, otherwise it will damage the emitter.

*The appearance and specifications of the product may be modified for improvement without notice.

Flux Characteristics at 140mA, T_j = 25°C

Radiation Pattern	Color	Part Number Emitter	Luminous Intensity (cd)	
			Minimum	Typical
Lambertian	Red	AL6A-RA1DF-D2	9.0	11.5

- ProLight maintains a tolerance of $\pm 7\%$ on flux and power measurements.
- Please do not drive at rated current more than 1 second without proper heat sink.

Electrical Characteristics at 140mA, T_j = 25°C

Color	Forward Voltage V _F (V)			Thermal Resistance Junction to Slug (°C/W)
	Min.	Typ.	Max.	
Red	1.85	2.20	2.45	13

- ProLight maintains a tolerance of $\pm 0.1V$ for Voltage measurements.

Optical Characteristics at 140mA, T_j = 25°C

Radiation Pattern	Color	Dominant Wavelength λ_D			Total included Angle (degrees) $\theta_{0.90V}$	Viewing Angle (degrees) $2\theta_{1/2}$
		Min.	Typ.	Max.		
Lambertian	Red	614 nm	616 nm	618 nm	160	120

- ProLight maintains a tolerance of $\pm 1nm$ for dominant wavelength measurements.

Absolute Maximum Ratings

Parameter	Red
Max DC Forward Current (mA)	200
Peak Pulsed Forward Current (mA)	350 (less than 1/10 duty cycle@1KHz)
LED Junction Temperature	125°C
Operating Temperature	-40°C - 110°C
Storage Temperature	-40°C - 110°C
Soldering Temperature	JEDEC 020c 260°C
Allowable Reflow Cycles	3
Reverse Voltage (T _s = 25°C)	10V
ESD withstand voltage acc. to ANSI/ESDA/JEDEC JS-001 (HBM, Class 2)	2000 V

Photometric Luminous Intensity Bin Structure at 140mA

Color	Bin Code	Minimum Luminous Intensity (cd)	Maximum Luminous Intensity (cd)	Typical Luminous Flux Φ_V (lm)	Available Color Bins
Red	J	9.0	11.2	30.3	All [1]
	K	11.2	14.0	37.8	

- ProLight maintains a tolerance of $\pm 7\%$ on flux and power measurements.
- The flux bin of the product may be modified for improvement without notice.
- ^[1] The rest of color bins are not 100% ready for order currently. Please ask for quote and order Possibility.

Dominant Wavelength Bin Structure at 140mA

Color	Bin Code	Minimum Dominant Wavelength (nm)	Maximum Dominant Wavelength (nm)
Red	2	614	618

- ProLight maintains a tolerance of ± 1 nm for dominant wavelength measurements.

Note: Although several bins are outlined, product availability in a particular bin varies by production run and by product performance. Not all bins are available in all colors.

Forward Voltage Bin Structure at 140mA

Color	Bin Code	Minimum Voltage (V)	Maximum Voltage (V)
Red	A	1.85	2.00
	B	2.00	2.15
	D	2.15	2.30
	E	2.30	2.45

- ProLight maintains a tolerance of ± 0.1 V for Voltage measurements.

Note: Although several bins are outlined, product availability in a particular bin varies by production run and by product performance. Not all bins are available in all colors.

Automotive

Color Spectrum, $T_j = 25^\circ\text{C}$

1. Red

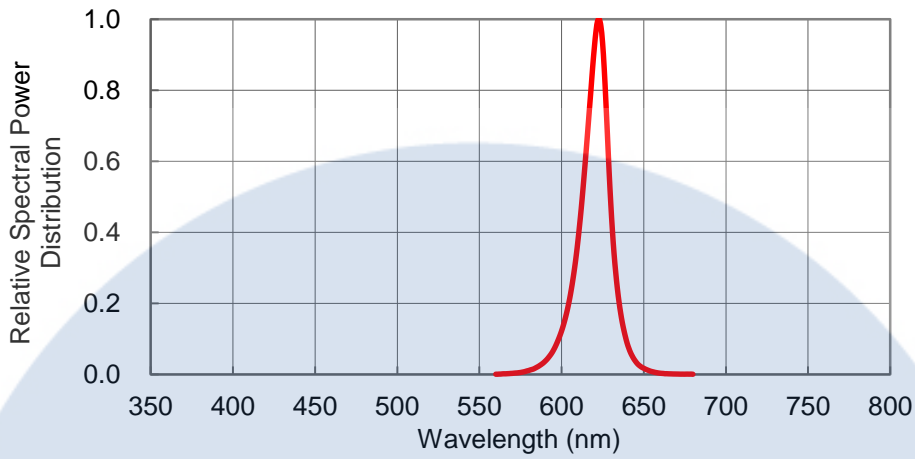

Light Output Characteristics

Relative Light Output vs. Junction Temperature at 200mA

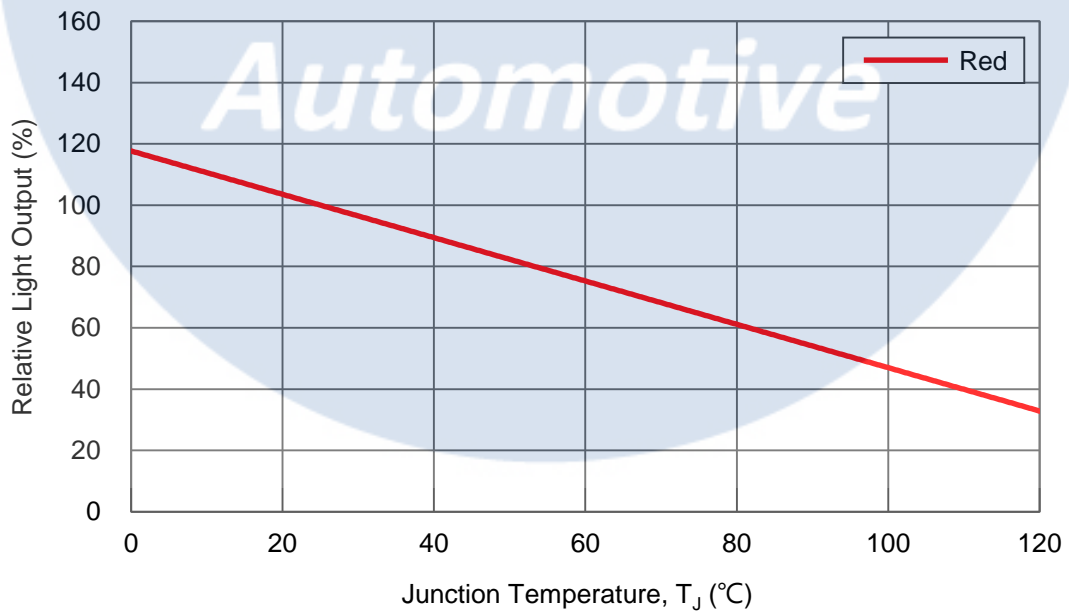

Forward Current Characteristics, $T_j = 25^\circ\text{C}$

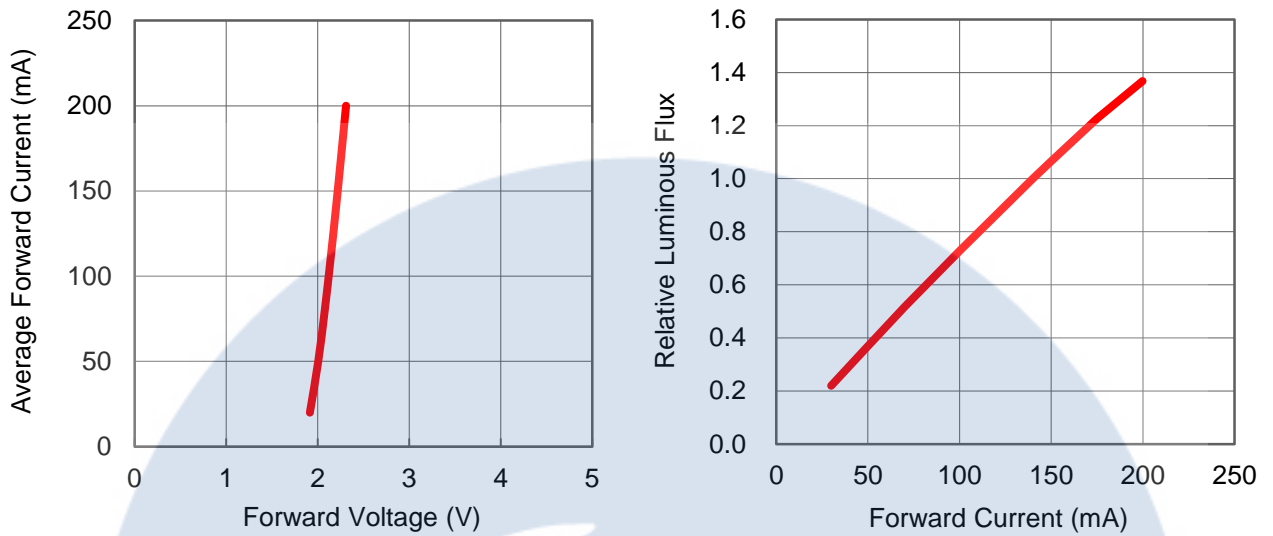

Ambient Temperature vs. Maximum Forward Current

1. Red ($T_{JMAX} = 125^\circ\text{C}$)

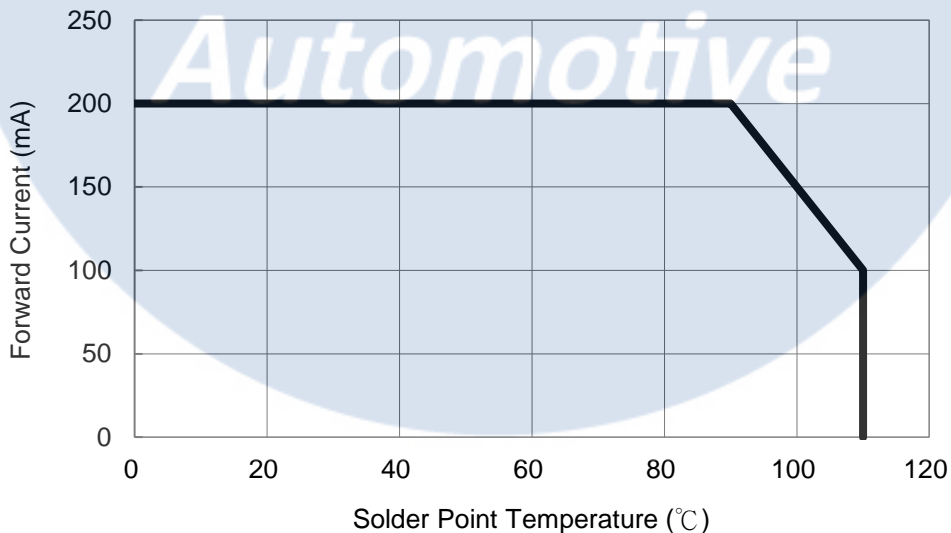

Typical Representative Spatial Radiation Pattern

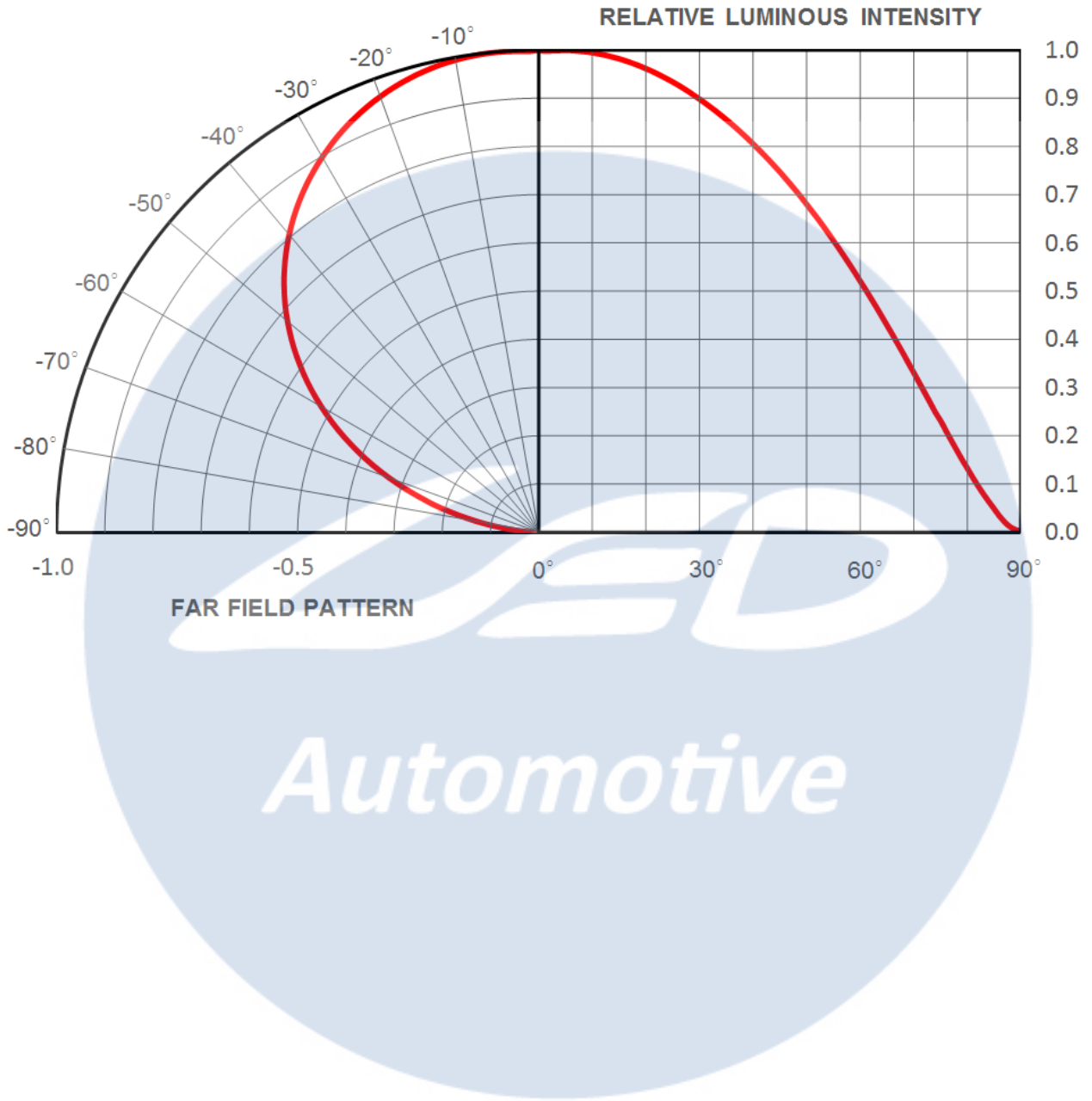

Moisture Sensitivity Level - JEDEC Level 2

Level	Floor Life		Soak Requirements			
			Standard		Accelerated Environment	
	Time	Conditions	Time (hours)	Conditions	Time (hours)	Conditions
2	1 year	≤30°C / 60% RH	168 +5/-0	85°C / 60% RH	NA	NA

- The standard soak time includes a default value of 24 hours for semiconductor manufacture's exposure time (MET) between bake and bag and includes the maximum time allowed out of the bag at the distributor's facility.
- Table below presents the moisture sensitivity level definitions per IPC/JEDEC's J-STD-020C.

Level	Floor Life		Soak Requirements			
			Standard		Accelerated Environment	
	Time	Conditions	Time (hours)	Conditions	Time (hours)	Conditions
1	Unlimited	≤30°C / 85% RH	168 +5/-0	85°C / 85% RH	NA	NA
2	1 year	≤30°C / 60% RH	168 +5/-0	85°C / 60% RH	NA	NA
2a	4 weeks	≤30°C / 60% RH	696 +5/-0	30°C / 60% RH	120 +1/-0	60°C / 60% RH
3	168 hours	≤30°C / 60% RH	192 +5/-0	30°C / 60% RH	40 +1/-0	60°C / 60% RH
4	72 hours	≤30°C / 60% RH	96 +2/-0	30°C / 60% RH	20 +0.5/-0	60°C / 60% RH
5	48 hours	≤30°C / 60% RH	72 +2/-0	30°C / 60% RH	15 +0.5/-0	60°C / 60% RH
5a	24 hours	≤30°C / 60% RH	48 +2/-0	30°C / 60% RH	10 +0.5/-0	60°C / 60% RH
6	Time on Label (TOL)	≤30°C / 60% RH	Time on Label (TOL)	30°C / 60% RH	NA	NA

Reliability testing in accordance with AEC-Q102

The development of this product included extensive operational life-time testing and environmental testing. Table 1 summarizes the tests applied and cumulative test results obtained from testing performed in accordance with AEC-Q102.

Table 1. Operating life, mechanical and environmental tests performed on it's package in accordance with AEC-Q102.

#	STRESS	ABV	Conditions	Duration	Failure Criteria	Rejects
<u>1</u>	Pre- and Post-Stress Electrical Test	TEST	Test is performed as specified in the applicable stress reference at room temperature.	N/A	See notes [2]	0
<u>A1</u>	Pre-conditioning	PC	Soak Tamb = 85 °C, RH = 85% Reflow soldering	N/A	See notes [2]	0
<u>A2a</u>	Wet High Temperature Operating Life	WHTOL 1	Tambient = 85 °C / 85% RH IF = max. DC [1]	1000 hours	See notes [2]	0
<u>A3a</u>	Power Temperature Cycling	PTC	-40°C to 85°C, 10 minutes dwell, 20 minutes transfer (1 hour cycle), 2 minutes ON/2 minutes OFF, IF = max. DC [1]	1000 hours	See notes [2]	0
<u>A4</u>	Temperature Cycling	TC	-40°C to 110°C, 15 minutes dwell	1000 cycles	See notes [2]	0
<u>C10</u>	Solderability	SD	245 °C ± 5 °C	3s	See notes [3]	0
<u>B1b</u>	High Temperature Operating Life	HTOL2	Maximum specified Tsolder, IF = max. DC [1]	1000 hours	See notes [2]	0
<u>G2</u>	Vibration Variable Frequency	VVF	10-2000-10 Hz, log or linear sweep rate, 20 G about 1 min., 1.5 mm, 3X/axis		See notes [3]	0
<u>G3</u>	Mechanical Shock	MS	1500 G, 0.5 msec. pulse, 5 shocks each 6 axis		See notes [3]	0

Notes:

1. Depending on the maximum derating curve.
2. Criteria for judging failure

Item	Test Condition	Criteria for Judgement	
		Min.	Max.
Forward Voltage (V_F)	$I_F = \text{max DC}$	--	Initial Level x 1.1
Luminous Flux or Radiometric Power (Φ_V)	$I_F = \text{max DC}$	Initial Level x 0.8	--
Reverse Current (I_R)	$V_R = 5V$	--	50 μA

* The test is performed after the LED is cooled down to the room temperature.

3. A failure is an LED that is open or shorted.

Recommended Solder Pad Design

Solder Pad

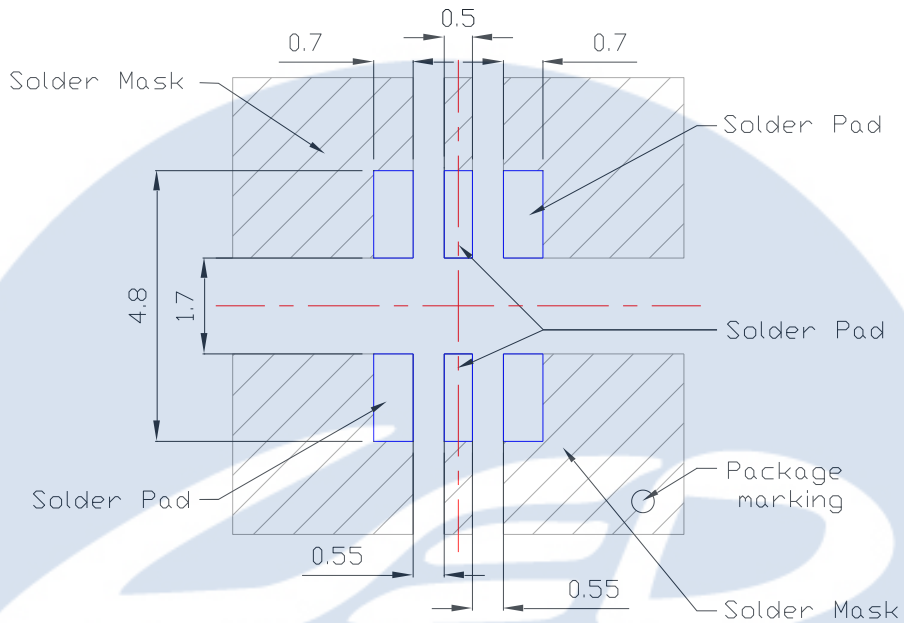

- All dimensions are in millimeters.
- Electrical isolation is required between Slug and Solder Pad.

Emitter Reel Packaging

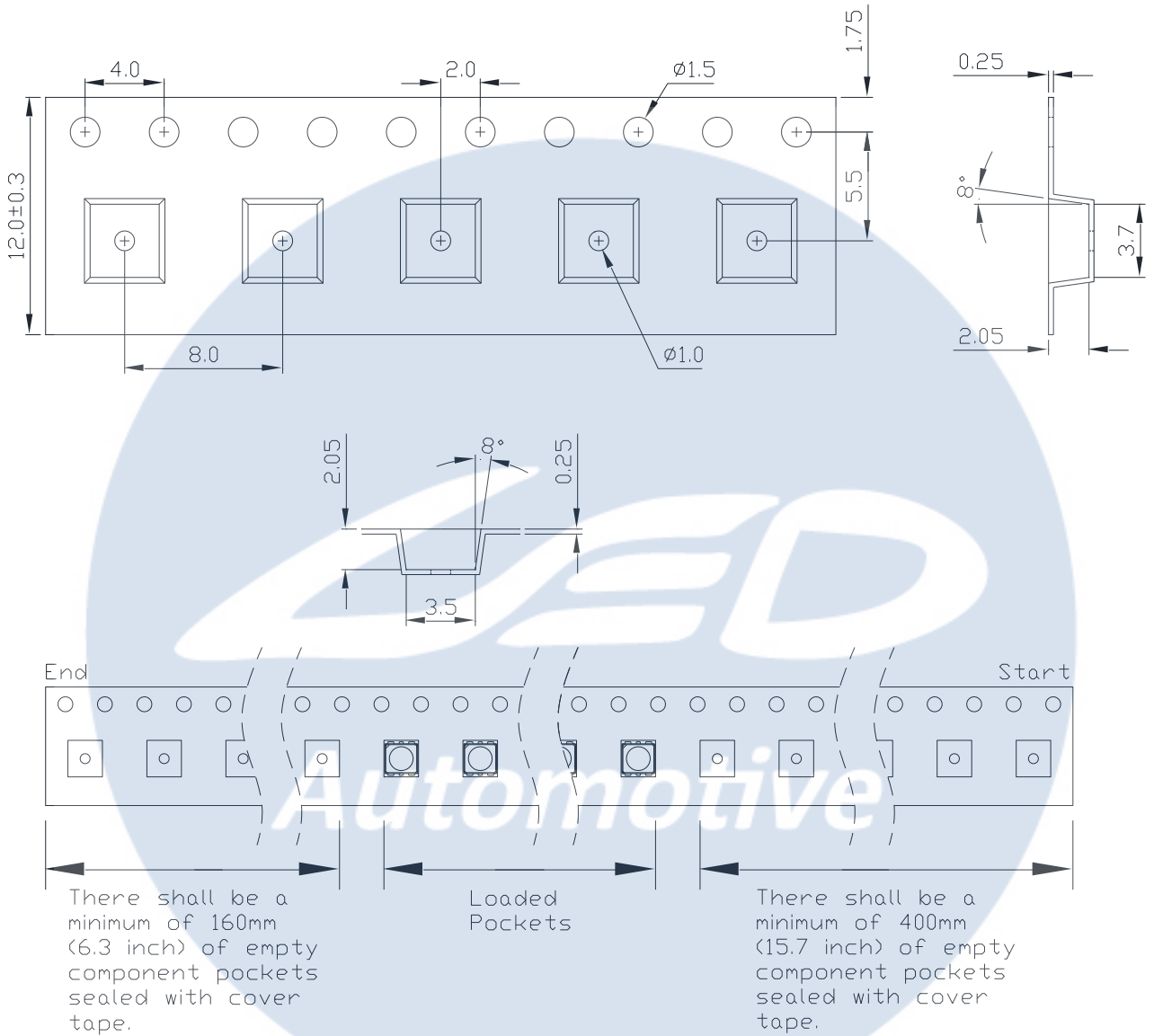

Notes:

1. Drawing not to scale.
2. All dimensions are in millimeters.
3. Unless otherwise indicated, tolerances are ± 0.1 mm.

Emitter Reel Packaging

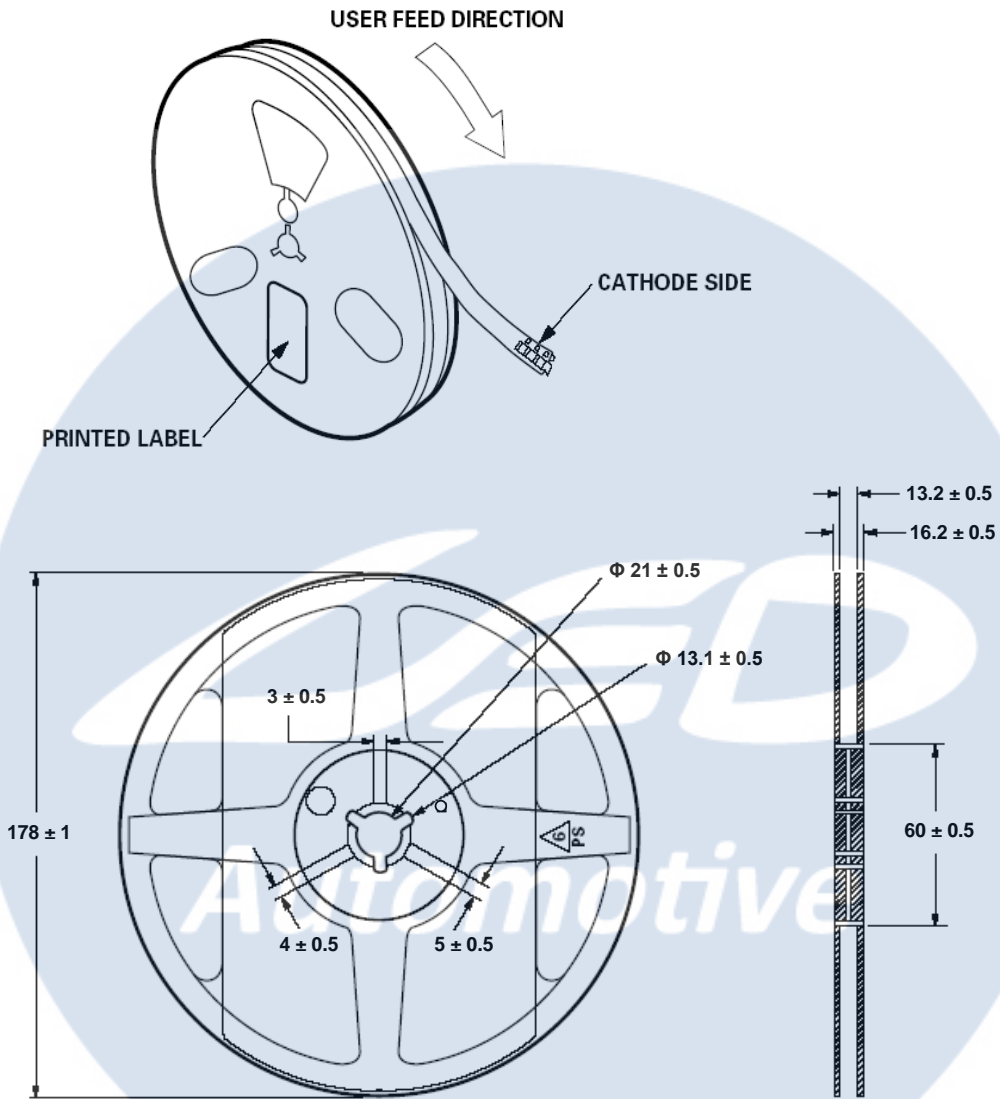

Notes:

1. Empty component pockets sealed with top cover tape.
2. 1000 pieces per reel.
3. Drawing not to scale.
4. All dimensions are in millimeters.

Precaution for Use

- Storage
Please do not open the moisture barrier bag (MBB) more than one week. This may cause the leads of LED discoloration. We recommend storing ProLight's LEDs in a dry box after opening the MBB. The recommended storage conditions are temperature 5 to 30°C and humidity less than 40% RH. It is also recommended to return the LEDs to the MBB and to reseal the MBB.
- **We recommend using the M705-S101-S4 solder paste from SMIC (Senju Metal Industry Co., Ltd.) for lead-free soldering.**
- **Do not use solder pastes with post reflow flux residue > 47%. (58Bi-42Sn eutectic alloy, etc) This kind of solder pastes may cause a reliability problem to LED.**
- Any mechanical force or any excess vibration shall not be accepted to apply during cooling process to normal temperature after soldering.
- Please avoid rapid cooling after soldering.
- Components should not be mounted on warped direction of PCB.
- Repairing should not be done after the LEDs have been soldered. When repairing is unavoidable, a heat plate should be used. It should be confirmed beforehand whether the characteristics of the LEDs will or will not be damaged by repairing.
- This device should not be used in any type of fluid such as water, oil, organic solvent and etc. When cleaning is required, isopropyl alcohol should be used.
- When the LEDs are illuminating, operating current should be decided after considering the package maximum temperature.

Handling of Silicone LEDs

Notes for handling of silicone lens LEDs

- The LEDs should only be picked up by making contact with the sides of the LED body.
- Avoid touching the silicone especially by sharp tools such as Tweezers.
- Avoid leaving fingerprints on the silicone.
- Please store the LEDs away from dusty areas or seal the product against dust.
- When populating boards in SMT production, there are basically no restrictions regarding the form of the pick and place nozzle, except that mechanical pressure on the silicone must be prevented.
- Please do not mold over the silicone with another resin. (epoxy, urethane, etc)

